



## Luxury. Style. Sophistication.

Large, vibrant Town & Country signature flames actively dance over the “invisible” burner of the new WideS54 See Thru to perfectly divide architectural space.

The WS54 See Thru features a completely illuminated burner, adding dynamic injections of up-light through the sparkling Diamond media and subtle downlight over tranquil stone and sand. With Town & Country’s unmatched power venting versatility, the WS54 See Thru can be located almost anywhere within a building envelope - even 110’ from an outside wall - and in peninsula installations.

### PRODUCT FEATURES

- Clean Face wide screen format
- Huge ceramic disappearing glass
- Create your perfect fire inside the firebox with Design-A-Fire
- Integrated Micro-Mesh Safety Screen
- Overhead LED Interior Lighting
- Up-lighting available with Diamond Burner Option
- Integrated Micro-Mesh Safety Screen
- Natural gas or propane
- Power Vented
- Versatile Installation up to 110 feet from an exterior wall with power venting
- Superior materials and construction
- Full integration with Smart Home Control Systems

Please note: Due to elevation and fuel type, flame characteristics may not be exactly as shown.

### FIREBOX PANEL OPTIONS

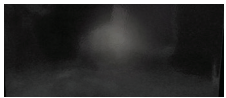

BLACK PORCELAIN

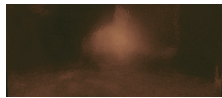

COFFEE BEAN BROWN PORCELAIN



COPPER PORCELAIN

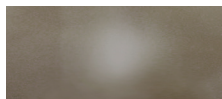

TITANIUM PORCELAIN

### BURNER OPTIONS



BLACK DIAMOND BURNER

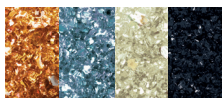

TUMBLED GLASS IN 4 COLORS



TRANQUILITY BURNER



RIVER ROCK IN 3 FINISHES

### DIMENSIONS (SERIES D)

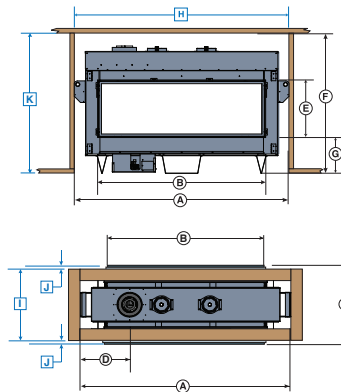

WS54ST		inch	cm
APPLIANCE DIMENSIONS	A	74 3/4	189.9
	B	54 7/16	138.3
	C	24 1/4 – 26 15/16	61.6 – 68.4
	D	16 7/16	41.8
	E	18 5/8	47.4
	F	54 1/16	137.3
	G	11 5/8	29.5
MINIMUM COMBUSTIBLE FRAMING DIMENSIONS (INCLUDING SHEETROCK)	H	75 1/4	191.2
	I	21 1/4 – 23 1/8	54.0 – 58.7
	J	1/2	1.3
	K	54 5/16	138.0
	L		
	M		
	N		